

Operating Manual

For the MELAG Autoclaves

MELAtronic[®] 17 **MELAtronic[®] 23**

Dear Doctor:

Thank you very much for the trust that you have shown in our products by purchasing this autoclave.

For 50 years now, MELAG — a medium-sized, family owned and operated business — has specialized in the production of sterilization equipment for medical practice. During this period, MELAG has succeeded in becoming a leading manufacturer of sterilization equipment. More than 335,000 MELAG units sold throughout the world testify to the exceptional quality of our sterilization systems — which are manufactured exclusively in Germany.

As all other MELAG products, this autoclave was manufactured and tested according to strict quality criteria. Before placing this unit into operation, please carefully read this Installation and Operating Manual. Also please carefully read the section on the proper preparation of instruments for sterilization. The long-term functional effectiveness and the preservation of the value of your autoclave will primarily depend on careful regular maintenance of this unit.

The staff and management of MELAG

The functional effectiveness and the preservation of the



value of this equipment will depend on:

- The proper preparation of the objects that you wish to sterilize
 - The prevention of rust being introduced to the system from the outside
 - The careful care of the equipment
 - The regular exchange of distilled or demineralized water.
-

Page

1	INTRODUCTION.....	2
1.1	ELEMENTS ON THE FRONT OF THE AUTOCLAVE	3
1.2	TECHNICAL DATA.....	3
1.3	PREPARATION OF INSTRUMENTS.....	4
1.4	RUST IN THE AUTOCLAVE: BROUGHT IN FROM THE OUTSIDE	4
1.5	CARE OF THE AUTOCLAVE	4
1.6	INSTRUCTIONS FOR CHECKING AND CARING FOR THE DOOR AND DOOR-LOCK COMPONENTS.....	5
1.7	FUNCTIONAL TESTING OF THE AUTOCLAVE	6
2	PLACING THE AUTOCLAVE INTO OPERATION	6
2.1	SETTING UP THE AUTOCLAVE	6
2.2	FILLING THE WATER STORAGE TANK.....	7
2.3	VDE REGULATIONS	7
3	INFORMATION FOR EVERY STERILIZATION CYCLE.....	7
3.1	OBJECTS BEING STERILIZED	7
3.2	THE STERILIZATION SEQUENCE.....	8
3.3	CHECKING TO ENSURE THAT THE CYCLE HAS PROPERLY RUN	8
3.4	ABORTING THE PROGRAM	9
3.5	REMOVAL OF DRY OBJECTS READY TO USE	9
3.6	FREQUENCY OF DAILY STERILIZATION	9
4	ADDITIONAL INFORMATION ON STERILIZATION	9
4.1	TOTAL OPERATING TIME (STERILIZATION CYCLE TIME)	9
4.2	USING DISTILLED OR DEMINERALIZED WATER.....	10
5	TROUBLESHOOTING.....	11
5.1	TROUBLE WITHOUT AN ERROR REPORT	11
5.2	MALFUNCTIONS WITH ERROR MESSAGES	12
6	SAFETY INSTRUCTIONS / WARNINGS	13
7	PLACING THE AUTOCLAVE OUT OF OPERATION / TRANSPORT INSTRUCTIONS / PLACING THE AUTOCLAVE BACK INTO OPERATION	14
8	ANNEX / SPARE PARTS	15
8.1	SPARE PARTS	15

1 Introduction

1.1 Elements on the front of the autoclave

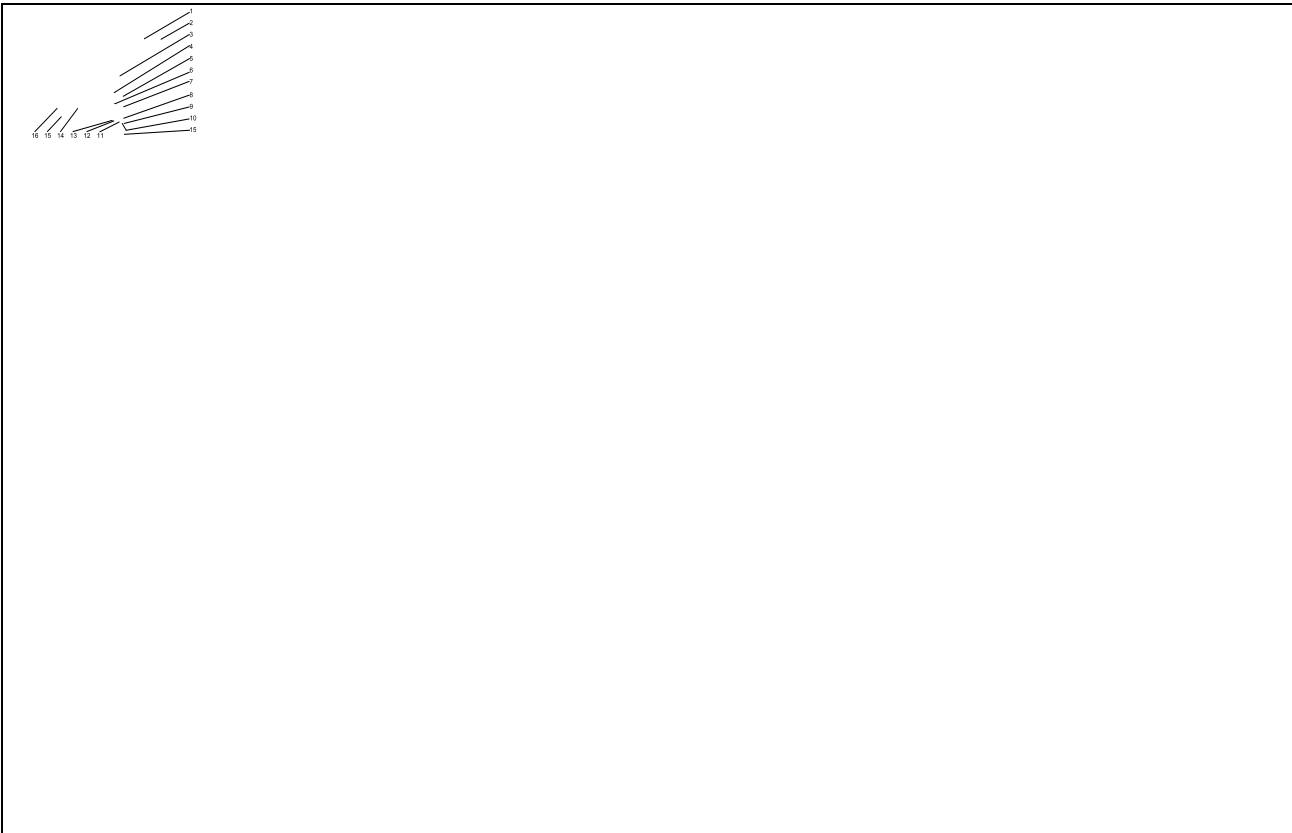

1	Enclosure lid	6	Switch for water feed	12	Lamp for "Heater is on"
2	Grating rack to hold the trays, etc.	7	Power switch	13	Lamp for "Cycle is running"
3	Pressure gauge	8	Display	14	Opening to check for water filling
4	Switch for program selection	9	Button to turn drying on	15	Adjustable feet of the unit
5	Switch to start program	10	Button to turn drying off	16	Drain for distilled water
		11	Show remaining run time / cancel error message		

1.2 Technical data

	MELAtronic®17	MELAtronic®23
Chamber dimensions (diam. × depth)	18 × 42 cm	23 × 45 cm
Loading capacity (incl. trays):		
Instruments	3 kg	4 kg
Textiles	200 g	Unwrapped, or wrapped in paper: 500 g In sterilization container: 300 g
Amount of water required per sterilization cycle	350 ml	400 ml
Parameters for Program 1 (121°C)	121°C, 1 bar, 25 min sterilization time	
Parameters for Program 2 (134°C)	134°C, 2 bar, 5 min sterilization time	
Overall cycle time:		
Program 1	40 minutes	45 minutes
Program 2	25 minutes	30 minutes
Drying time	Can be selected as required	
Waiting time between sterilization cycles:	15 minutes	15 minutes
Electrical ratings: AC	230 V / 1350 W	Model for 230 V / 1970 W Model for 110 V / 1600 W
Backup fuses (2 for each unit)	16 A FF	Model for 230 V: 16 A FF Model for 110 V: 20 A FF

1.3 Preparation of instruments

MELAG non-rusting materials

All parts of MELAG autoclaves that come into contact with steam are made of non-rusting materials. The sterilization chamber, the water tank, and the tray rack are made of stainless steel. The steam lines are of copper; the sterilization-chamber door, of chrome-plated brass; and the trays, of anodised aluminium.

Rust dragged in from the outside

The use of these materials means that the autoclave itself cannot produce rust. When rust does attack the autoclave or sterilized objects, investigations have always consistently shown that this rust is dragged in by instruments when they enter the autoclave. It must be remembered that even stainless-steel instruments from leading manufacturers can develop rust: for example, after improper treatment with chemical cleaning and disinfecting agents during instrument preparation.

Preparation of the objects to be sterilized

The problem of rust dragged in from the outside shows how important it is to properly prepare the objects to be sterilized. The following preparation instructions are absolutely essential to ensure proper sterilization:
After instruments are used, they must immediately

be disinfected and cleaned in a disinfection and/or cleaning agent, according to UVV/VBG 103. Be sure to use the correct dosage of the agents, and to leave the instruments in the solution for the prescribed length of time. We also recommend using such aids as ultrasonic devices and thermal disinfectors.

Important: It is essential that the instruments be properly cleaned before disinfection, to avoid debris separating from the instruments under steam pressure and clogging the nozzles and valves of the autoclave. Latches, catches, joints, and hinges must especially be cleaned very thoroughly with a brush. Completely rinse off cleaning and disinfecting agents under running water, while using a brush, before putting the instruments into the autoclave.

Warning: Do not by any means allow any residue of chemical substances from cleaning and disinfecting agents to enter the autoclave, since they will cause corrosion. As last step, finally rinse the instruments with demineralized water, dry them carefully, and place them into the autoclave.

New instruments being sterilized for the first time

The above-described cleaning procedure must also be used for brand-new instruments, since they often carry small amounts of oil, grease, and debris from their production processes.

1.4 Rust in the autoclave: brought in from the outside

As described above, this autoclave itself cannot rust owing to the kind of materials of which it is made. Any rusty spots in the autoclave are "dragged-in rust": from instruments or other metal objects with rusty spots. This can occur on standard steel whose electroplating is damaged, or even on stainless-steel objects. Often, only one single rust-emitting instrument is enough to cause rust to develop on other instruments or in the autoclave. Dragged-in rust will then transfer to other instruments or parts of the autoclave, and will spread from there. This is why

the sterilization chamber must be regularly wiped out to prevent dragged-in rust from remaining on the surface and further developing. Dragged-in rust must be removed from the sterilization chamber, the water tank, and from the tray rack. We recommend using stainless-steel cleansers such as product Sidol or an equivalent. **Warning:** Do not use steel wool or steel brushes. To clean the sterilization chamber, first pull the tray rack out of the chamber. **Important:** Do not sterilize rusty instruments.

1.5 Care of the autoclave

Required each week

Cleaning of the sterilization chamber

You must clean the sterilization chamber and the door seal on the chamber at least once a week. First take out the trays, and then pull the tray rack out of the chamber. Wipe out the chamber with a soft cloth or sponge. For stubborn stains, use stainless-steel cleaner such as Sidol. **Caution:** Make sure not to let such cleaning agent enter the piping that leads out of the sterilization chamber. Also wipe only in the direction of the surface structure. Do not use steel brushes or pot cleaners made of metal. The cleaning agents must not contain chlorine, and must not be alkaline. You can remove spots from stainless steel by using a 5% solution of oxalic acid.

Door seal

Check the door seal once a week for damage. Clean the seal with normal, commercially available liquid cleansers.

Every two weeks

The water tank (for distilled or demineralized water)

Every two weeks, drain the distilled or demineralized water from the tank by opening the drain cock (16). Clean the water tank if necessary: for example, with a bottle brush, warm water, and a grease-cutting agent. Rinse out with water and fill with fresh distilled or demineralized water (see Section 4.2 for water quality).

1.6 Instructions for checking and caring for the door and door-lock components

In order to prevent premature wear, the threaded spindle of the palm grip hand knob, as well as the hinges of the latch yoke and the door locking bar, must always be kept well greased. We recommend plain-bearing grease (MELAG article no. 24355), silicone grease, or Molykote.

The following drawings indicate trouble that may occur and that may be the result of excessive wear on the door locking system. If any of these difficulties occur, inspection will be necessary by a MELAG Customer Service representative, or by an authorized technician from a specialist dealer.

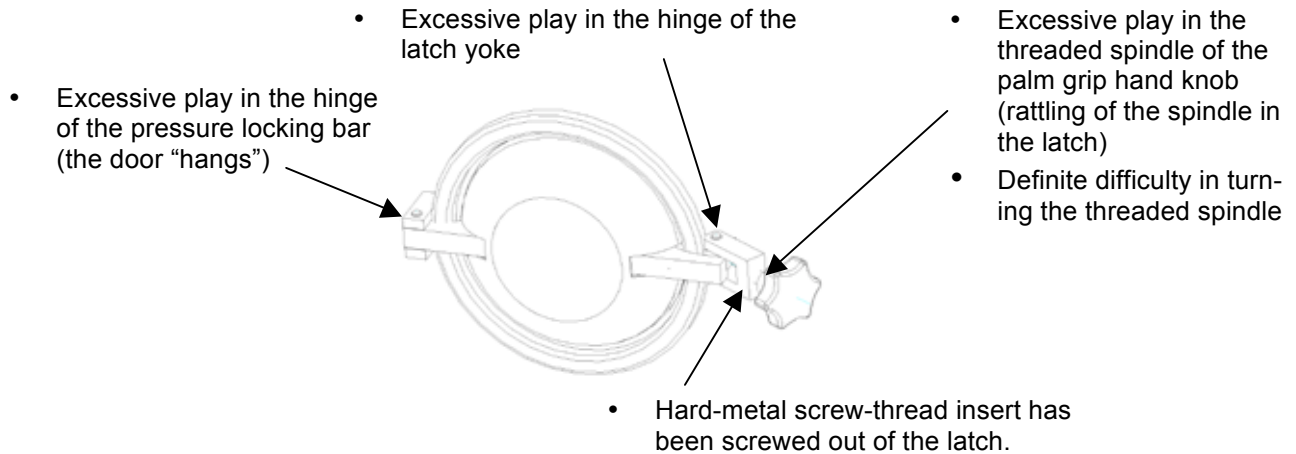

Important:

The hinge bolts must by all means remain inserted completely in the latch and in the hinge yoke of the pressure locking bar (left side). The bolt must be flush as shown.

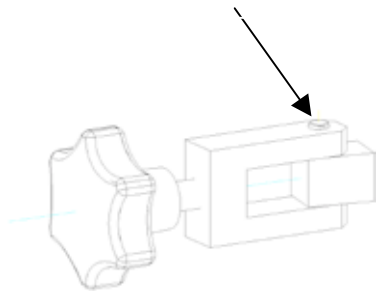

If this bolt moves up or downward and is no longer flush with the yoke (as shown in proper position in left drawing), do not use the autoclave. It must be repaired by Technical Customer Service personnel.

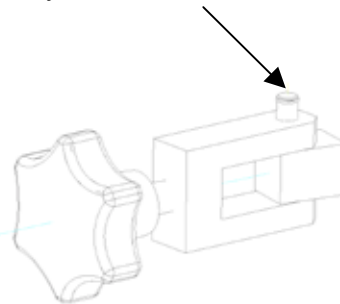

1.7 Functional testing of the autoclave

Regular checks

The microprocessor control for the MELAtronic automatically monitors sterilization temperature and time. You can check the pressure gauge during sterilization (white pointer). After sterilization, the red non-return (slave) pointer will show the maximum pressure reached. If there is no error message in the display at the end of the program, and if the red non-return pointer is between 1 and 1.3 bar for Program 1 (121°C) or between 2 and 2.4 bar for Program 2 (134°C), and if the loading instructions have been correctly observed (see Sections 3.1 and 3.2), then you can assume that effective sterilization has taken place.

Periodic checks (every six months)

German standard DIN 58 946, Part 8, Section 3.2, recommends:

“Period testing should take place at the site of use, at recommended intervals of six (6) months. The purpose of testing is to verify that the small-size sterilizer effectively sterilizes upon observance of operating instructions.”

Hygiene institutes and state medical laboratories will provide test spores upon request. They analyse these spores and provide test results on a test form. DIN 58 946, Part 4 and DAB 10 (official German Pharmacopoeia), stipulate that *Bacillus Stearothermophilus* spores (for example, the product ATCC 7953, Paper Spore Strips, supplied by the company Oxoid, Cd. number BR 23), must be used to test steam autoclaves.

As stipulated, five bioindicators (plus a positive sample) are necessary to test the MELAtronic® 17/23 (chamber volume > 5 dm³), in accordance with

DIN 58 946, part 8.

If the test spores already are already packed (for example, spore strips in paper packs, test tubes, or the product Attest), **do not pack them again in additional enclosures** when you place them in the autoclave.

When conducting a spore test, the most stringent sterility precautions are necessary to prevent recontamination. For example, after sterilization do not pack the spore packets into the same envelopes used to send them to you. Also do not use the same tweezers after testing as before. We recommend sterilizing the tweezers along with the test spores. To avoid falsifying your results in making your analysis, do not allow the non-sterilized positive sample to come into contact with the sterilized test spores. For transport purposes, you can also submit your positive sample in a paper package that you have also sterilized.

Important note:

If the test spores are in a tube that is perforated only on one side (for example, the product Attest by 3M), then observe the following:

Never place these tubes into the autoclave with the perforation pointing upward (with Attest, the perforation is in the brown closure cap). Since this autoclave functions by the gravitation principle, the perforation should ideally point downward: but at least toward the side (as is the case for tubes).

If you are using “handmade” test-spore products that are directly sealed in a paper-film package, then ensure that the paper sides are freely exposed to the steam. The paper sides of the package should likewise point to the side or downward.

2 Placing the autoclave into operation

2.1 Setting up the autoclave

Electrical connection

The autoclave must be powered from a separate circuit. This circuit must be additionally protected by a quick circuit breaker.

Open intervals to the sides

The autoclave must be set up with an open interval of at least 10 cm from the nearest walls. The open space above the autoclave should be at least 30 cm. It is very important for proper sterilization that the autoclave be correctly set up. The following instructions must therefore be very carefully followed: both for the first installation, as well as for any change in location.

Correct: setting up on a perfectly level surface

This MELAG autoclave uses its own, direct supply of water. This convenience makes it very important that the autoclave operate on a perfectly level surface. The sterilization chamber is installed inside the autoclave at a certain angle of slope to the rear, which means that the distilled or demineralized water becomes visible through the opening to check for filled

for filled water (14) only after the required amount of water has flowed into the chamber.

Incorrect: setting up on a surface sloping toward the front of the autoclave

If you try to install this autoclave on a surface that slopes to the front of the autoclave, the distilled or demineralized water will already become visible at the front of the sterilization chamber, through the opening to check for water filling (14), before enough water has flowed in. This means that there will not be enough distilled or demineralized water to achieve the proper pressure of 2 bar in the chamber, and for this pressure to be maintained approx. 5 min. – or that a pressure of 1 bar cannot be maintained constant for the required time of action of 20 min.

Incorrect: setting up on a surface sloping toward the rear of the autoclave

If you try to install this autoclave on a surface that slopes toward the rear of the autoclave, the distilled or demineralized water will become visible at the

front of the sterilization chamber, through the opening to check for water filling (14), after too much water has flowed in. The excess water not consumed during sterilization will then remain in the chamber (which, however, will not impair autoclave functions).

Adjusting the level of the autoclave

To make sure that the autoclave has been installed on a perfectly level surface, it is delivered with a

2.2 Filling the water storage tank

Take off the enclosure lid (1) on the housing of the autoclave, and then remove the cover of the water storage tank.

Fill the water tank with approx. 3 litres of distilled or demineralized water. Do not fill above the line marked "MAX". Make sure that the cooling coils in the water storage tank are always covered with water. This will allow the outstreaming steam to con-

2.3 VDE regulations

According to the presently valid VDE regulations (Society of German Electrical Engineers), these autoclaves may not be operated in **areas subject to explosion hazards**.

These autoclaves may be repaired only by the manufacturer or by personnel expressly authorized

graduated test cup. To make this adjustment, fill 350 ml of distilled or demineralized water from the cup into the front of the sterilization chamber of the MELAtronic®17 (or 400 ml of water for the MELAtronic®23). The autoclave is perfectly level if the filled water is visible at the opening to check for filled water (14) of the tray rack. If the autoclave is not level, adjust it by turning the front feet (15) up or down.

condense, will prevent unpleasant steam effects, and will reduce the consumption of distilled or demineralized water. For this reason, always keep the level of water filled above the coils. Or, better, drain off the remaining water through the drain for distilled water (16), and then fill up to the "MAX" level with distilled or demineralized water.

by the manufacturer (specialist dealers or Customer Service).

DANGER !

The edge of the door, the edge of the sterilization chamber, and the sterilized objects **become very hot** during operation.

3 Information for every sterilization cycle

3.1 Objects being sterilized

Tray racks must be used

To prevent the danger of overheating of the sterilized items by the heat radiated from the sterilization chamber, these autoclaves must not be operated without using a closed MELAG tray rack. These trays, other supports on which the sterilized items are placed, and containers for these items (with or without covers) must be perforated.

Sterilization packages

The items for sterilization can also be sterilized in sealed see-through sterilization packaging: for example, MELAfo[®] (with one side paper and one side transparent film). During sterilization, the paper side of the packs must face downward. These packs must not be placed on top of each other on a tray. For better drying, we recommend lining up the see-through sterilization packs vertically, like cards in a card-file box: for example, in a MELAG Package Holder (MELAG article no. 283; **this product fits only in the MELAtronic®23**). When sealing the sterilized items in a package, make sure that the sealing seams are at least 8 mm wide (as stipulated

by DIN 58953). The MELAG MELAseal[®]100/101 Package Sealing Devices produce a sealing seam 10 mm wide.

Sterilized items that are sensitive to heat

IMPORTANT: When sterilizing plastic articles, make sure not to exceed the maximum sterilization temperature as given by the manufacturer. By no means allow heat-sensitive products (such as dental aspirator tubes) to come into direct contact with the tray rack of the autoclave. The rack becomes very hot from the heat radiated from the sterilization, and this can damage such sensitive items.

Always place plastic articles (such as aspirator tubes) on the middle tray. We recommend not placing heat-sensitive items directly onto the autoclave tray, but on a sheet of filter paper.

Liquids

Warning: These autoclaves are not suited for the sterilization of liquids.

3.2 The sterilization sequence

1. Switch on the power switch

Switch on the autoclave by the power switch (7). The autoclave will then test the electronic systems and will display the interior temperature of the sterilization chamber.

2. Reset the red non-return (slave) pointer

Set the red non-return (slave) pointer of the pressure gauge (3) to "0".

3. Load the autoclave

Loosely load the trays or the sterilization containers with the objects to be sterilized, and slide in. "Loosely" means the following, for example: do not load textiles that are tightly folded, and do not tightly press them into the sterilization containers. Do not load more items than allowed (see Technical Data for limits).

4. Select the sterilization program

Use the switch for program selection (4) to choose the desired program.

Use Program 1 to sterilize heat-sensitive objects (of rubber, textiles, etc.) at 121°C.

Use Program 2 to sterilize bulky instruments (of metal, glass, etc.) 134°C.

5. Fill the water

Set the switch for water feed (6) to "I" (green lamp now shows) and wait until the water becomes visible at the opening to check for filled water (14). When it becomes visible, set switch (6) to "0".

6. Close the door

Close the door. Swivel the latch over the door locking bar, and lock the door by tightly screwing down the palm grip hand knob.

7. Start the program

Start the program by pressing the Start button (5). The display (9) will briefly confirm the program start by showing "Run". The lamp for "Cycle is running" (13) and the lamp for "Heater is on" (12) will show at the same time.

8. Program run

The program will now run fully automatically. The display will continuously show the steam temperature in the sterilization chamber. After the air-removal phase (approx. 15 min; temperature approx. 100°C), the heating-up time will follow. The pressure and temperature will rise to the parameters required by the specific program. When the minimum temperature is reached (121°C for Program 1 and 134 °C for Program 2), the actual sterilization phase will begin. The sterilization time will now begin to run: 20 min for Program 1, and 5 min for Program 2. To find out how much time remains in the current sterilization run, press the time button (11).

During the sterilization period, the autoclave control system will maintain the sterilization temperature for Program 1 at 122°C and for Program 2 at 136°C.

9. End of the sterilization cycle

At the end of the sterilization cycle, quick pressure release will automatically take place. The lamps for "Heater is on" (12) and "Cycle is running" (13) will go out.

10. Open the door

Check the pressure gauge to make sure that the pressure has been completely released. Then you can safely open the door.

11. Drying and removing the sterilized objects

If the sterilized objects are wrapped, you must leave the autoclave door slightly open for a few additional minutes to allow sufficient drying. In addition, you can also activate the drying function by pressing button "▲" (also see Section 3.5). After the objects have dried, you can remove them from the autoclave and switch off the heating by pressing button "▼".

Warning: The sterilization compartment, the door, and the sterilized objects are very hot. You must use the MELAG Tray Handle to remove the objects, or you must wear heat-protection gloves during this operation.

3.3 Checking to ensure that the cycle has properly run

If there is no error message on the display at the end of the program, and if the non-return pointer is between 1 and 1.3 bar for Program 1 (121°C) or

between 2 and 2.4 bar for Program 2 (134°C), then the program cycle has correctly run.

3.4 Aborting the program

You can abort (terminate) the program at any time. Proceed as follows:

1. Push both of the following buttons, below the display, at the same time: the button to turn the drying function off (10), and the time button (Show remaining run time, button [11]). The following error message will appear on the display:

“Err2”. At the same time, the quick pressure release procedure will automatically take place.

2. Observe the pressure gauge until the pressure falls to “0”.
3. Acknowledge the error message by pressing the time button (11).
4. You can now open the autoclave door.

3.5 Removal of dry objects ready to use

Observe the following steps to ensure obtaining dry, sterilized objects ready to use from the autoclave:

1. Wait until the quick pressure release has automatically taken place, and the reading on the pressure gauge has fallen to “0”.
2. Open the door of the autoclave slightly and leave it ajar.
3. Press the button  to turn on the drying function. The display will now show “Dry”, alternating with the interior temperature of the sterilization chamber.
4. Wait until the sterilized objects are as dry as you require.

5. End the drying function by pressing the button .

Filter paper

Experience has shown that optimal results are obtained by placing a sheet of filter paper on the tray, then the objects to be sterilized, then on top of the objects a second sheet of paper.

Do not use gauze or other types of cellulose for this purpose

Do not use saturated cellulose products or gauze instead of filter paper as described above. The steam of the autoclave can dissolve substances in cellulose and gauze that will deposit in the form of spots on the sterilized objects.

3.6 Frequency of daily sterilization

You can use MELAG autoclaves to sterilize up to approx. eight (8) cycles per day. This large number of sterilization cycles is made possible by the MELAG system, which evaporates and re-condenses only a relatively small amount of distilled or demineralized water per sterilization cycle.

Waiting period between sterilization cycles

When a sterilization cycle finishes, a waiting period of at least fifteen (15) minutes must be observed between the end of the one program and the beginning of the next.

4 Additional information on sterilization

4.1 Total operating time (sterilization cycle time)

Operating times:

- Program 1 (1 bar at 121°C): 35 ... 45 min
- Program 2 (2 bar at 134°C): 20 ... 30 min

When you begin the program with the “Start” button (5), the program will begin and run fully automatically. The actual sterilization time itself will begin to run only when the respectively required sterilization temperature has been reached. Since the air-removal time and the heating-up time until reaching of the required sterilization temperature will depend on the loading of the autoclave, and on the temperature of the sterilization chamber when the cycle starts, the total operating time is not fixed and will vary within the two ranges given above.

Times included in the total operating time

The total operating time (i.e., the overall time, or cycle time) includes the individual time sequences

such as heating-up time, ventilation time, temperature-rise time and equilibration time, and the sterilization time. Sterilization time consists of the kill time and the safety-margin period.

Drying time and drying temperature

Drying time: as desired

Drying temperature:

- Mantle of sterilization chamber: approx. 120°C
- Interior of sterilization chamber: approx. 60°C

The mantle of the sterilization chamber is kept constantly at 120°C during the drying period. When the heating system is on, “Dry” will appear on the display, alternating with the interior temperature of the sterilization chamber. You can deactivate the drying function by pressing the button to turn it off (10).

4.2 Using distilled or demineralized water

Water quality requirements

For steam sterilization, it is necessary to use steam-distilled water (aqua dest) or fully demineralized water (aqua dem).

Please observe the following guideline data for the quality of the water that you use; this data is in accordance with the CEN standard DIN EN 285:

Conductivity	≤	15	μS/cm ^{*)}
Evaporation residue	≤	10	mg/l
Silicon and SiO ₂	≤	1	mg/l
Iron	≤	0.2	mg/l
Cadmium	≤	0.005	mg/l
Lead	≤	0.05	mg/l
Heavy metals, except for the above	≤	0.1	mg/l
Chlorides	≤	2	mg/l
Phosphates	≤	0.5	mg/l
pH value		5 ... 7	
Water colour		Colourless, clear, without residue	
Hardness	≤	0.02	mmol/l
Important note:			
The use of feed water with constituents at greater concentrations than those given above can greatly shorten the service life of an autoclave, and can nullify the manufacturer's guarantee.			

*) μS/cm = microsiemens per centimetre

4.2.1 Amount of water consumed

After each sterilization cycle, the water in the autoclave storage tank will be reduced by the amount of steam that does not completely condense. The exact amount of losses will depend on a number of circumstances:

Factor: time interval between sterilization cycles

Water consumption will depend on the time between sterilization cycles. If the distilled or demineralized water in the storage tanks remains warm as a result of continuous sterilization, the steam emitted from

4.2.2 Refilling with fresh water

Dirty water in the storage tank

The water in the storage tank will become quickly dirty if the instruments are not carefully cleaned before each sterilization process. You must regularly check the water in the storage tank for cleanliness. If the water is dirty and murky, or if there is a surface film on the water, or if there

For operation of the MELAtronic[®]17/23 autoclaves, **fully demineralized water in accordance with VDE 510** is also sufficient, if this water meets VDE regulations (i.e., conductivity after water treatment ≤ 10 μS/cm^{*)}; conductivity upon use ≤ 30 μS/cm^{*)}; pH value as set forth in DIN EN 285; evaporation residues similar to those set forth in DIN EN 285).

Sources of water

Demineralized water is available on the commercial market in accordance with VDE 510. The label of the purchased container must specifically verify that the water meets classification specifications as set forth in VDE 510.

Poor water can damage the autoclave

If poor-quality water is used, scale deposits (calcium carbonate, CaCO₃) in the steam lines, the valves, and the vent nozzle can impair the functions of the autoclave.

Formation of spots

The extent of spots produced on sterilized instruments will depend on the quality of the water used to produce the steam. For steam sterilization, it is necessary to use steam-distilled water (aqua dest) or fully demineralized water (aqua dem).

the sterilization chamber will not completely condense. Part of this steam will escape from the storage tank.

Cooling coils

If a long time has passed since distilled or demineralized water has been refilled, and if the water level in the storage tank has dropped below the cooling coils, the emitted steam will also not fully condense, and will escape.

is a coating on the bottom and walls of the tank, then you must by all means replace the distilled or demineralized water in the tank. If there are greasy deposits in the tank, we recommend filling the storage tank with warm water containing a grease cutter (the German product Pril or an equivalent), and cleaning out the tank with a bottle brush. Then rinse out with fresh water (for water quality, see Section 4.2 above).

4.2.3 Emptying the water storage tank

You can drain out dirty water from the storage tank by opening the drain (16) for distilled water (turn to the left), and allowing the dirty water to flow into a container. First, attach the supplied drain hose to the sleeve of the drain (16).

Close the drain by turning to the right, and fill the storage tank up to the "MAX" level with approx. three (3) litres of distilled or demineralized water.

5 Troubleshooting

The following instructions will help you to correct minor malfunctions. They will also help you to give an exact description of more serious trouble to your

specialist MELAG dealer, your MELAG depot, or the MELAG Customer Service representative.

5.1 Trouble without an error report

5.1.1 No display

If you switch on the power to the autoclave, and if nothing appears in the display, then check the following:

1. Check to make sure that the power cable is properly plugged into the power socket.
2. Check to see if there power at the socket.

3. Check the fuses at the rear of the autoclave. If they have blown, replace them. **Danger:** Before opening the fuse mounts, unplug the power cable. Replace with the spare fuses on the rear wall of the autoclave

5.1.2 No pressure display / Low reading on the pressure gauge

If, after a sterilization cycle, the red non-return (slave) pointer does not show at least the pressure required for the selected program, and if there is no error message on the display, then the pressure gauge or the red pointer of the gauge are probably

defective. If so, the pressure gauge must be replaced.

If you replace the pressure gauge, and if the pressure indication is still too low, then the trouble is in the temperature-control system (temperature sensor / electronic controller).

5.1.3 High reading on the pressure gauge

The red non-return pointer jams (fails to move)

It is possible that the red non-return will jam (stick), and will fail to move. This may be caused if the white pointer will try to drag along the "jammed" red pointer, and if the pressure is great enough to "knock away" the red pointer. The red pointer will then not stand at the maximum pressure reached in the sterilization, but will remain at the point where the white pointer has knocked it. This means that the red pointer will show a pressure that the autoclave has not reached in its cycle (for example, 4.5 bar). In such a case, you can check to see the actual pressure achieved in the autoclave by standing in front of the autoclave and watching the white pointer during a sterilization cycle.

Insufficient ventilation

If the pressure gauge shows a pressure that is considerably higher than 1.3 bar for Program 1, or higher than 2.4 bar for Program 2, then you must check the ventilation functions of the autoclave. Check as follows:

1. Check to see if the feed-water filter in the sterilization chamber is dirty.
2. Check to see if the vent nozzle in the water storage tank is stopped up.
3. Check to see if the solenoid valve for pressure release opens during the ventilation phase.

If these checks show that the ventilation process is OK, and if the pressure on the gauge is still too high, then the pressure gauge or the electronic temperature-control is defective.

5.1.4 Poor drying

Cause: you have not loaded the autoclave correctly

Do not load the autoclave with more items than the maximum specified amount. Be sure to arrange the items on the trays so that the condensation can properly run off.

Cause: you have not left the door slightly open

To achieve good drying, you must leave the autoclave door slightly open at the end of sterilization.

Cause: too much water remains in the sterilization chamber

It is not possible to avoid leaving a small amount of water in the sterilization chamber after the cycle. When the autoclave cools, the residual steam (no longer under pressure) will condense on those surfaces that cool off first: the door and the bottom of the chamber. The water will then collect at the bottom of the chamber. The following can cause excessive water to collect:

- The filter of the sterilization chamber is dirty.
- The solenoid valve that controls the water feed leaks.

Cause: leak in the solenoid valve for water feed

If the instruments are not properly cleaned before sterilization, small particles of debris can cause the solenoid valve for water feed to slightly leak. The autoclave may still be able to reach the required pressure, but water may drip from the water tank into the sterilization chamber after sterilization. The problem here is not actually too much residual water. Check for a valve leak as follows: Take out the tray rack and wipe completely dry the inside of the sterilization chamber. After a few hours, the chamber should still be completely dry. If the chamber is wet, clean out the solenoid valve by blowing it with air.

5.1.5 Overheating

Overheating is almost always caused by too little water in the sterilization chamber. If the autoclave overheats:

- Switch off the autoclave
- Open the door and allow the autoclave to cool down for 30 min

Before putting the autoclave back into operation, check for the following possible causes:

Loading

When textiles are sterilized, they absorb a great amount of steam and water. For this reason, never put more textiles in the autoclave than allowed.

Never operate the autoclave without the tray rack.

Vent nozzle

If instruments are not properly cleaned before sterilization, particles of debris will enter the distilled or demineralized water and, in turn, the steam. If the

autoclave is then used frequently for long periods of time, these particles together with the long and intensive action of the debris in the flowing air and steam will cause the vent nozzle to “wash out”. This means that the vent opening will be enlarged, and that excessive steam will be lost. In such a case, the vent nozzle must be exchanged.

Solenoid valves

If the instruments are not properly cleaned prior to sterilization, debris will enter the solenoid valves for water feed and for quick pressure release, and will cause them to leak.

Safety valve

The safety valve is located in the water storage tank, below the upper part of the U-shaped bow of the “MAX” water-level mark. If this safety valve trips at pressure-gauge readings of less than 2.5 bar of steam, then it must be replaced.

5.1.6 Malfunctions with error messages

If any of the following error messages appear, you must first acknowledge the message by pressing the button to show remaining run time / cancel error message (11), located below the display. After the

cause of the error has been eliminated (operator fault or technical defect), then you must start the program again.

5.1.7 The error message “Err1”

This error message means that the monitored time for the heating-up phase has exceeded its limit. Check for one of the following possible causes if “Err1” appears:

Too many items have been loaded

Make sure by all means that you do not load more than the maximum amount allowed in these instructions.

Water-feed switch was not activated

The water feed switch was not activated, or it was not switched off after a sufficient amount of water has entered the sterilization chamber.

The door is not tightly sealed

Close the door tightly. If necessary replace the door seal (gasket).

The vent nozzle is “washed out”

If the orifice of the vent nozzle has become washed out, it will be too large for the autoclave to reach the required pressure. In such a case, replace the nozzle.

Leaks in the valves

The solenoid valves for water feed and for quick pressure release may be clogged and leaky. The pressure-release valve may also have a leak. See

The overheating protection function has tripped

Check the position of the jacket heating unit. This unit should be pushed as far in as it can go at the bottom rear fitting of the sterilization chamber.

The heating system is defective

An electrical check of the heating system is necessary.

5.1.8 The error message “Err2”

You have aborted the running program

The error message “Err2” will appear after a program has been started, and if the user then presses the button to turn the drying function off (10) and the button for program selection (4).

Program selection

The error message “Err2” will appear if you start one program, and then use the switch for program selection (4) to choose another program.

The power has failed

The error message “Err2” will appear if you start a program, and if the power to the autoclave fails (i.e., if the building power fails, or if you switch off the autoclave by its power switch).

Temperature leaves required range

The error message “Err2” will appear if the actual temperature has left the range required for the selected program (temperature too high or too low).

5.1.9 Error message “1999”

This message will appear if the temperature sensor is defective (the cable has broken, or there is a

short circuit).

6 Safety instructions / Warnings

Warning: After opening the autoclave door, do not touch exposed hot metal parts. Use the MELAG Tray Handle to remove hot trays, and use suitable heat-protection gloves to remove other sterilization containers.

Drain the water out of the water storage tank before transporting the autoclave. Do not tip the autoclave if there is water in its tank.

Do not open the door of the autoclave until you are sure that there is no pressure inside. It is safe to

open the autoclave if the pressure gauge shows “0”.

Danger: Small amounts of hot steam can escape the autoclave and burn users.

These autoclaves may be repaired only by persons authorized by MELAG, and only with original MELAG spare parts. **Danger:** Never open the enclosure of the autoclave without first pulling the plug of the power cable.

These autoclaves are not suited for sterilization of liquids.

7 Placing the autoclave out of operation / Transport instructions / Placing the autoclave back into operation

To place these autoclaves out of operation, and to transport them, observe the following:

- Pull out the plug of the power cable. Allow the autoclave to cool down.
- Drain the water out of the storage tank by opening the drain plug (16).
- If you transport the autoclave while the tray racks and/or the trays themselves are still inside, you must protect the polished door of the autoclave from being damaged. Place foam rubber between the racks or trays and

the door: or use some other suitable material such as Bubble Wrap®.

- When you place the autoclave back into operation after moving or repairing it, follow the instructions given above in Section 2, "Placing the autoclave into operation".

Important: To avoid damaging the autoclave during transport, be sure to use its original packaging.

8 Annex / Spare parts

8.1 Spare parts

Article no.	Description of article
34125	Vent nozzle (with M6, SW 8 threads)
16005	Safety valve (officially calibrated)
32670	Door seal, for MELAtronic®17
34150	Door seal, for MELAtronic®23
34010	Filter for sterilization chamber
35496	Temperature sensor for steam
34165	Pressure gauge
58740	Overheating protection unit (installed on the sterilization chamber)
57592	Fuse: 16 A FF for models designed for 230 V operation
57590	Fuse: 20 A FF for models designed for 110 V operation